

TBEW Battery series Electric Torque Wrench

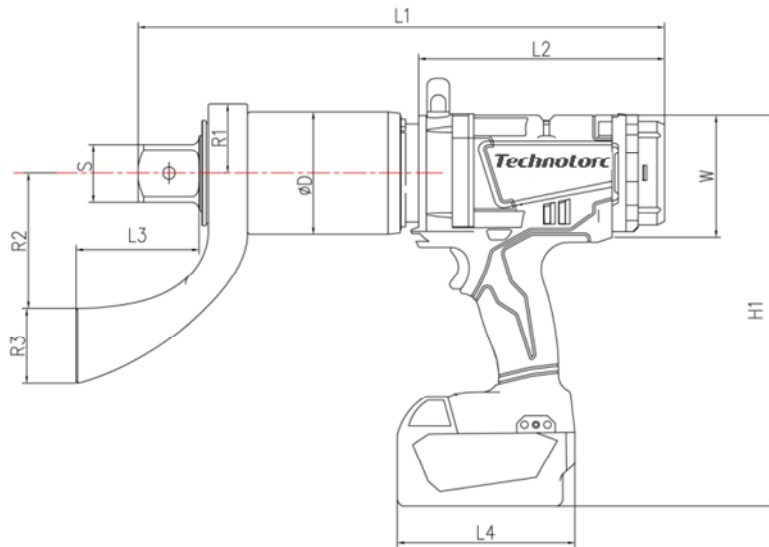

Model	Min torque (N.m)	Max torque (N.m)	S	D	L2	L1	H1	L4	W	R1	R2	R3	L3	weight (Kg)	Max speed rpm
					mm										
TBEW-05S	100	500	1/2"	63	163	280	260	110	80	34	56	43	46	4.6	27.5
TBEW-08S	100	800	3/4 "	65	163	287	260	110	80	34	56	48	48	4.8	17
TBEW-16S	200	1600	1 "	69	163	327	260	110	80	36	70	58	60	5.8	7
TBEW-20S	200	2000	1 "	69	163	327	260	110	80	36	70	58	60	5.8	5.6
TBEW-30S	500	3000	1 "	82	163	340	260	110	80	46	80	68	80	7.4	3
TBEW-40S	700	4000	1-1/2 "	88	163	355	260	110	80	46	80	68	80	8.3	2.4
TBEW-60S	1000	6000	1-1/2 "	92	163	412	260	110	80	55	93	65	95	10.9	1.4
TBEW-80S	2000	8000	1-1/2 "	103	163	435	260	110	80	55	93	65	95	12.7	1.1

Remark:

1. Digital display cordless electric torque wrench is a product that includes a numerical display and digital torque settings, data recording
2. Programmable preset torque value, torque and angle setting
3. Standard with 2 * 18V5Ah lithium batteries and a fast charger; optional 9Ah lithium battery
4. Accuracy up to $\pm 5\%$
5. Using brushless DC motor